



2016-2017 Centre Officiating Booklet

Little Athletics Association of
Victoria Incorporated

REVISION DATE: August 2016

TABLE OF CONTENTS

PREFACE	1
OFFICIALS EDUCATION PATHWAY	2
YOUR ROLE AS AN OFFICIAL	3
MANAGING & COMMUNICATING	4
STARTING.....	5
TIMEKEEPING.....	7
PLACE JUDGING	9
HURDLES.....	10
TRACK UMPIRING	11
COURSE MARSHALL	13
RELAYS.....	14
RACE WALKING	16
HIGH JUMP	19
LONG JUMP	22
TRIPLE JUMP	25
DISCUS.....	27
SHOT PUT.....	29
JAVELIN.....	31
EQUIPMENT SPECIFICATIONS.....	34
OTHER RESOURCES	35

PREFACE

This booklet is primarily aimed at new parents, carers and other interested people of little athletes who have shown an interest in assisting Centres to run their weekly Centre competitions. It outlines basic processes and rules of the various events provided at Centres at their weekly competitions.

The booklet is designed to accomplish three aims:

Firstly, to introduce parents, carers and other interested people to the rules and events offered at Little Athletics;

Secondly, to provide a basic toolkit of knowledge to conduct activities at a Little Athletics Centre;

Thirdly, and more importantly, it aims to provide an indication of the spirit in which the rules should be applied and how the activities are delivered at Centre level competitions.

We thank you for your time and effort in volunteering to help the children participate in this exciting sport. Your contribution is very much appreciated.

Enjoy your involvement with Little Athletics and good luck.

OFFICIALS EDUCATION PATHWAY

You will find throughout this booklet a reference to the relevant IAAF/LAVic rules for a particular role or event. The rules listed are the key rules you may want to refer to for that event or position.

For Region & State competitions Little Athletics Victoria use the same rule naming convention, terminology and processes as the IAAF 2016-207 Competition Rules Book. Where it was decided the IAAF Rule was not indicative or correct for athletes in the age groups covered by LAVic, the IAAF Rule or part thereof was rewritten to reflect the nature and abilities of athletes in the various age groups. These modified rules form the LAVic Regulation 8 Version 2.0 (Released August 2016) and are for use at Region & State events. We encourage Centres to use these rules as guidelines at their Centre competitions.

By using the same rules, terminology & processes it enables a better understanding for officials and athletes from their initial introduction to athletics through to more advanced competitions and other athletic bodies.

The following diagram maps out the official's education pathway in Victoria.



VICTORIAN OFFICIALS PATHWAY - GRASSROOTS TO INTERNATIONAL



OFFICIALS	Anyone	Club/Centre/ School Official	State Official	National Official	IAAF Technical Officials
OVERVIEW	Introduction to Officiating (an Australian Sports Commission course)	Basic Grading – aimed at officials wishing to officiate at a local/ club/ centre/school level	Aimed at officials wishing to be appointed as a Chief or Referee at State level and a Chief at National level	Aimed at Officials wishing to be appointed as a Chief or Referee or Competition Management at a National level	IAAF Technical Officials Education Certification Scheme TOECS Level 2 (Diploma) conducted by the Oceania Regional Development Centre IAAF Technical Officials Education Certification Scheme TOECS Level 3 (Diploma) conducted by the IAAF
EVENT		CLUB / SCHOOL	STATE CHAMPS	NATIONAL CHAMPS	MAJOR CHAMPS
LEVELS	LEVEL 0	LEVEL 1	LEVEL 2	LEVEL 3	LEVEL 4 & 5

FOR MORE INFORMATION VISIT WWW.LAVIC.COM.AU – EDUCATION AND TRAINING - OFFICIALS

Information correct as of 21.09.2015

YOUR ROLE AS AN OFFICIAL

You may think that your role as an Official at your local Little Athletics Centre is to officiate the rules of the event. Actually, your role is much more than this. Primarily, your role as an Official is to:

- Facilitate the opportunity for children to compete, have a go and enjoy athletics.
- Ensure that all children are safe.
- Help all children improve.
- Create a fun environment to which children will want to return.

Officiating junior sport is not the same as officiating senior sport. It is extremely important that everybody associated with Little Athletics is very clear with this point. Children are not little adults. The differences are:

- The child comes first, not the rules.
- Officials at junior sport need to apply the rules to match the skill levels of the child and the activity.
- The simpler the skill level, the more simple and relaxed are the rules and their interpretations.
- Be consistent, fair and objective when making decisions, giving the benefit of the doubt to the child.
- Be courteous when making decisions, use it as a learning experience for the child. If they have done something the wrong way, show them the right way and give them another attempt.
- Compliment and encourage all participants – officials are role models and a source of confidence building for a child.
- Ensure that the activity is conducted within "the spirit of the game" and that sportsmanship underpins all actions.
- Always remember that officials in junior sport have a big responsibility. As a child's first foray into organised sport, a positive experience will help set in place a lifetime of involvement. Likewise a negative experience can severely impact on that child's involvement in any future physical activity.

MANAGING & COMMUNICATING

Through completing the Introduction to Officials Course and reviewing this document, volunteers should have the knowledge and competence to conduct an event at Little Athletics. However, this only covers the technical side of running an activity; the more important side is being good at managing and communicating with groups of children and other volunteers.

Managing & Communicating With Children

There are a number of points to remember when officiating children:

COMMUNICATION

Children are not little adults. When communicating, remember:

Children don't respond to instructions in the same way adults do. Instructions have to be clear, simple and have practical meanings. Don't leave the interpretations of instructions up to the child.

Think about the words you use. In understanding a message, adults can use a range of skills that aren't available to children. Adults can interpret words in the context of the message/situation, watch your body language and gestures and draw from past experiences. Children more often than not, take the verbal word literally. The words you use should reflect literally what your message is.

Always be encouraging, children are very good at remembering experiences. If they break a rule, be encouraging, supportive and directional in the language you use. Officiating should be a form of instruction on how to do it right.

Sarcasm or being critical in a joking way isn't something that children have learnt to interpret well; it should not be used.

MANAGING GROUPS OF CHILDREN

Points to remember:

- Children want to be active; asking them to stand quietly in line for periods of time to await their turn isn't often successful. Try and keep them active when it's not their turn. As an example, you can provide them with basic practice drills or warm up activities for the event.
- Don't try to do it all by yourself, encourage parents to become involved. Every child is to be supervised the whole time. Don't allow children to wander off.

Managing & Communicating With Other Volunteer Helpers

As an Official, you will often find yourself as the person conducting the event. You will have other volunteers to help you with the tasks of officiating.

COMMUNICATION

Communicating with the other assisting volunteers is very important. Points to remember are:

Before the start of the event, explain that the level of officiating will match the skill level and age of the children.

Set the tone for how the activity will be conducted and how relaxed rule interpretations are.

Be clear with any points that may be subjective, e.g. the shot put action, so that all officiating is consistent.

Explain the roles of the helpers and the exact tasks you'd like them to do. Don't assume they already know. People are sometimes reluctant to ask for help if they feel it is embarrassing to be naive.

Be friendly, everybody is there to enjoy themselves.

MANAGING

Always thank people for their assistance and point out the fact it's through their effort the children will have/have had an enjoyable experience. People like to feel appreciated.

Don't lump responsibility onto people who don't have the knowledge or experience in a certain field. It can cause all kinds of problems and will usually result in potential volunteers being lost.

Take the time to get to know new volunteers.

Allow and encourage new helpers to make suggestions. Don't enforce things just because that's the way it's always been done.

STARTING

(Related IAAF/LAVic Rules: Rule 129, 130, 161, 162)

Note: Within Little Athletics Victoria is a committee called the LAVic Starters Panel. This panel is responsible for the further education of starters, by conducting seminars. Should you be interested in learning more about starting races, you can contact the Starters Panel through the LAVic Office.

Starters Safety Issues

- **Noise hazard:** Caused by the firing of "Cap Guns" means that good quality industrial ear plugs/muffs must always be used.
- **Fire Hazard:** The "Caps" used in starting guns are a potential fire hazard and must only be carried in a suitable container such as a leather pouch, plastic or wooden box.

Equipment

- **Stand:** To provide an elevated position and view of all lanes, ideally a stand should always be used but this may not be the case at all Centres or for all events.
- **Starting Device:** Where an electronic starting device is being used ensure it is in good working order (including sufficient batteries) and is connecting correctly to the timing device being used. Where a gun (and caps), are being used, the gun should be reloaded with caps after every start.
- **Whistle:** As a warning device that start procedure is about to begin.
- **Ear Plugs:** Of good quality as guns are noise hazards.
- **Flash Board:** Dark background to make smoke detection easier.
- **Communication Device:** For contacting other officials such as Timekeepers, etc.
- **PA system:** To ensure that all athletes can hear starter's instructions particularly for events using "staggered" starts, e.g., 400m. May be a "loud hailer"
- **Identifying Colour / Uniform:** LAVic Approved Polo Top with optional "arm band" or "cap".

Note: For Starters at **Centre level** the polo top will be the current LAVic sponsored Polo Top and for **Region & State Championship events** this will be the Victorian Officials Polo Top.

Location of Starter

- **Straight Line:** (Laned events up to and including 100m). Located on the infield slightly in front of the athletes to enable all to be viewed at the narrowest angle of practicable
- **Staggered Start:** (Laned events up to and including 800m). Located in a position so that all athletes are in one line of vision, may need voice amplification to enable athletes to hear starter.
- **Curve Line:** (Unlaned events). Similar to above but may need to be located in different position to enable all athletes to be viewed clearly depending on whether the start is on a bend or in the straight.

Note: When the Starter moves to a new position, they need to check with the Timekeepers to ensure that they are clearly visible.

Function

- To ensure that each start is fair and gives each athlete an equal opportunity to perform to the best of their ability.
- To control, alone or with the assistance of Recall Starter, all aspects of starting to achieve the above.
- Alone or with the support of Recall Starter and/or Starters Assistant allocate athletes to heats and lanes.
- Alone or with the assistance of Recall Starter nominate athlete(s) who have made a false start "break" and issue a "warning".

Starting Procedure

- Starter indicates procedure is about to commence by blowing a whistle, then the start commands as follows:
- For laned events:
 - **"On Your Marks"**
 - **"Set"**
 - **"Start Signal"**
- For unlaned events (including the 800m started in lanes):
 - **"On Your Marks"**
 - **"Start Signal"**

Note: Some Centre's run unlaned events for younger age groups that are 400 metres or less.

- It is permissible for the athletes head and torso to be past the plane of the start line.
- The start signal is not given until the Starter is satisfied that all athletes are steady. If the waiting time for athletes to be steady becomes excessive the command **"Stand Up"** may be given, this command cancels the start procedure. Additionally obstructions on the track or issues with the starting gun may require the command **"Stand up"** to be given.
- If a false start occurs, i.e., one or more athletes gain an advantage ("break" or "fly") a second "Start Signal" is fired to abort the start ("false start" or "recall" signal).
- Offending athletes are warned by the Starter and/or Recall Starter, a second (or third) false start by any previously warned athlete may lead to their disqualification.

Note: The number of false starts that leads to disqualification can vary across Centres, for State Championship rounds, athletes are disqualified after 2 false starts.

Recall Starter

FUNCTION

- To assist the Starter in all aspects of starting as follows:
- Issue signals that indicate the readiness or otherwise of the athletes allocated to them.
- Issue a second "Start Signal" to abort the start if one of their allocated athletes gains an unfair advantage, "false starts".
- One or more Recall Starters may operate to assist the Starter. Ideally for staggered starts there should be at least two. Recall Starters are placed so they can see each athlete allocated to them.
- Alone or with the support of Starters Assistant return athletes to start line after a false start.

Starters Assistant

FUNCTION

- Controls the preparation of the athletes in an event (heat or final) in readiness for passing onto the Starter.

DUTIES

- Allocate athletes to heats as follows:
- Count athletes to determine number & size of heats as required, e.g., for 100m - 17 athletes = 2 x 6 & 1 x 5.
- Allocate athletes to heats according to selection criteria, e.g., graded or random.
- Allocate athletes to lanes, e.g., randomly according to a random list, or by the drawing of lane numbers.
- As required, either alone or with the assistance of Recall Starter return athletes to start line after a false start.
- Assemble athletes up to three metres behind the start line, signal to the Starter that all is ready.
- Ensure the first athletes in a relay event have a baton.

TIMEKEEPING

(Related IAAF/LAVic Rules: Rule 128, 164, 165, 167)

Function

- To measure the elapsed time between the start and the finish of an event conducted on a track or course.

Note: If Place Judges are being used, Timekeepers will not act as Place Judges.

Definitions

Start: The first sign of a visual signal or smoke from the starting device.

Finish: When any part of the athlete's torso reaches the plane of the finish line.

Torso: Any part of the body (as distinct from the head, neck, arms, legs, hands or feet).

Officials Required

- Depends on the type of event, i.e., laned or unlaned, the equipment in use and the associated finishing system employed, i.e., manual (buttons) or automatic (gates), or fully integrated photo finish.
- Ideally, three Timekeepers record results for first place in manual timing. How these three performances are taken will vary depending on what timing equipment is in use and also whether the event is laned or unlaned/course.
- If the three performances differ, the middle time is accepted as the "performance" for recording and record purposes.

Preparation

- Become familiar with the operation of the timing device and practice a few times (see Types of Timing Equipment).
- Clarify which race and what place you are timing - be alert at all times. The Chief Timekeeper will normally advise when the start is imminent.

Duties of Chief Timekeeper

- Ensure that Timekeepers are placed in a suitable position
- Know what place to time
- Are in line with the finish line
- Have a good view of all lanes
- Have a clear view of the starter.
- For laned events timekeepers are usually in an elevated position on a stand at least five metres from the track.
- For unlaned events, all timekeepers will operate from the same side of the track and will be in line with the finish line, and if available in an elevated position.
- Communicate with the Chief Starter or "Track Official" when timekeepers are in position and ready.

Types of Timing Equipment

- Standard:** Simple stop/start device may have a third button for resetting otherwise successive presses of the stop button causes the watch to reset.
- Lap Timer:** Similar to a stop watch but has a third button for lap-timing, which when pressed stops the watch and when pressed again picks up the running time. Can be used to time two children with the lap button timing the first and the stop button timing the second. When the lap button is pressed again the watch shows the time that the stop button is pressed.
- Multi-Function:** A further variation of the "lap timer" which has the ability to record and store many times that can be recalled after the finish of the event. Some versions have an integral printer attachment for printing out the times of all athletes either as each time is recorded or after the event has finished.

- **Timing Machine:** Many variations exist, most of which can be started either by the starting device and/or manually (by an operator). These devices are typically stopped by each timekeeper pressing a button on individual leads or mounted in a bar (button bar) or by the use of "gates" which automatically detect the "torso" crossing the line using multiple electronic beams. Some of the devices are capable of capturing ten performances in performance or lane order. Some have printers attached for printing out the results.

When in use these devices require an operator to reset the device and the operator may also be required to manually transcribe the performances (Time Recorder).

Laned Track Events (Manual Timing)

USING "STOP WATCHES":

- Hold it between the thumb and forefinger with forefinger on the button. Hold the watch still to eliminate waste motion.
- Always look at your watch prior to the event start to ensure that it has been reset after the previous event or following a false start.
- Never reset your watch after capturing a performance without prior agreement being reached with either the Chief Timekeeper or all other timekeepers.

USING "TIMING MACHINES":

- Keep thumb (for individual buttons) or index finger (for button bars) on button. There is no reset ability for the timekeeper; this is handled by the operator. Take care with pressing the button as successive pressing of the button may cause the earlier time to be overwritten by the latter one.
- With about 30 metres of the race still to run note the identity of the athlete in the place you are timing and prepare to stop the watch. Do not anticipate the finish.

Unlaned/Course Events ("Running Watch")

- In unlaned (distance) or course (cross-country) events it is not necessary or practical to time each runner individually.
- **Using "Stop Watches":** One timekeeper may use two watches and as the winner finishes, one watch is stopped for an accurate measurement of first across the line and the second watch is kept running and as each other athlete crosses the line, times are called by the Timekeeper and recorded by a Time Recorder standing next to the Timekeeper. Alternately only a single watch may be used and all times called to the Time Recorder.
- **Using "Multi-Function Watches":** One watch can be used to record and store all results with each result subsequently recalled and relayed to the Time Recorder or if the watch has an integral printer the times are recorded and printed as each athlete crosses the line. Once the last athlete has finished the printout is then given to the Time Recorder to process.
- Use of a Multi-Function watch provides more accurate times as the "running watch" technique usually means that times are recorded to 1 second rather than 1/100 secs which is the standard for State Championships.

PLACE JUDGING

(Related IAAF/LAVic Rules: Rule 126.2, 164)

Function

- To determine the order in which athletes cross the finish line in a track/course event.

Note: The decisions of Judges take precedence over those of Timekeepers in respect to finishing order.

Definitions

- Finish:** When any part of the athlete's torso reaches the plane of the nearer edge of the finish line.
- Torso:** Any part of the body (as distinct from the head, neck, arms, legs, hands or feet).
- Finish Line:** A vertical plane across all lanes and usually marked by a vertical post on the inside and outside of the track.
- Dead Heat/Tie:** When the appropriate judges agree that the torso of two or more athletes reaches the finish line together.

Note: Equal performances does not necessarily indicate a tie or dead heat, e.g., at 12.50 secs for 100m athletes with equal times can be up to 8cm apart (a distance easily detected by the human eye).

Officials Required

- The number required depends on the type of event (Laned or Unlaned). The State Championships will require a minimum of nine Place Judges, unless fully automatic timing equipment totally integrated with photo finish is in operation.

Priority of Nomination

- Laned Events:** Ideally there should be one Judge for each athlete plus the Chief Judge. The Chief Judge selects first across the line, the next Judge selects first and second, the next selects second and third, etc.
- If there is a dispute between the Judges, e.g., two Judges claim the same athlete; the selection of Judge for the higher "place" has priority.
- Should such a situation arise the Chief Judge may ask other Judges to nominate their selections and by a process of elimination determine which athletes are unclaimed.

Duties of Chief Judge

- Ensure that Judges are placed in a suitable position.
- Know what place(s) to judge and understand "priority of nomination".
- Be in line with the finish line.
- Have a good view of all lanes.
- Have a clear view of the track. For laned events Judges are usually in an elevated position on a stand at least 5 metres from the track.
- Communicate with the Chief Starter or Track Official when Judges are in position and ready.
- Communicate with the Chief Timekeeper.

Note

- The single function of Judges may vary depending on the type of meeting, at which they are Officiating, e.g., at normal Centre competition, Timekeepers may also perform the role of Judges.
- Where an Official has a dual role of Judge and Timekeeper it is important that the Official does not lose sight of "their" athlete until identity is clearly established.

HURDLES

(Related IAAF/LAVic Rules: Rule 168)

Preparation for Event

- Ensure adequate numbers of Hurdles (flights) are on the track at the correct distance apart and at the correct height for the age group, (according to specifications on pg. 34).
- Check the track conditions. In wet conditions, grass tracks in particular can become very slippery, which can make Hurdles a very dangerous event for the athletes. Safety is paramount in all events.

Equipment

- The hurdles should be made of metal with the top crossbar of wood or other suitable material, with two feet and two uprights supporting the crossbar.
- Refer to specifications below for details of construction.
- Refer to page 36 for event specifications.

General Rules

- The feet of the hurdle will be at right angles to the crossbar and will be placed on the track, so that the edge of the crossbar nearest the approaching athlete coincides with the track marking nearest the athlete.
- In order for the athletes to check their start and hurdle clearance, athletes are normally permitted a practice trial over the first two hurdle flights.
- All races will be run in lanes and each athlete must keep to their own lane throughout the race.
- An athlete who trails a foot or leg below the horizontal plane of the top of any hurdle at the instant of clearance will be disqualified.
- If an athlete jumps any hurdle not in their own lane they will be disqualified.
- If in the opinion of the Referee, an athlete deliberately knocks down any hurdle, they will be disqualified.
- The unintentional knocking down of hurdles will not result in disqualification, nor prevent a record being set.

Officials required

Officials/Umpires are required to observe from directly down the track for any lane infringements, or to notice any interference with other athletes. Additionally, Officials/Umpires adjacent to the hurdle flights are required to observe athletes when they are attempting to clear the hurdles for infringements.

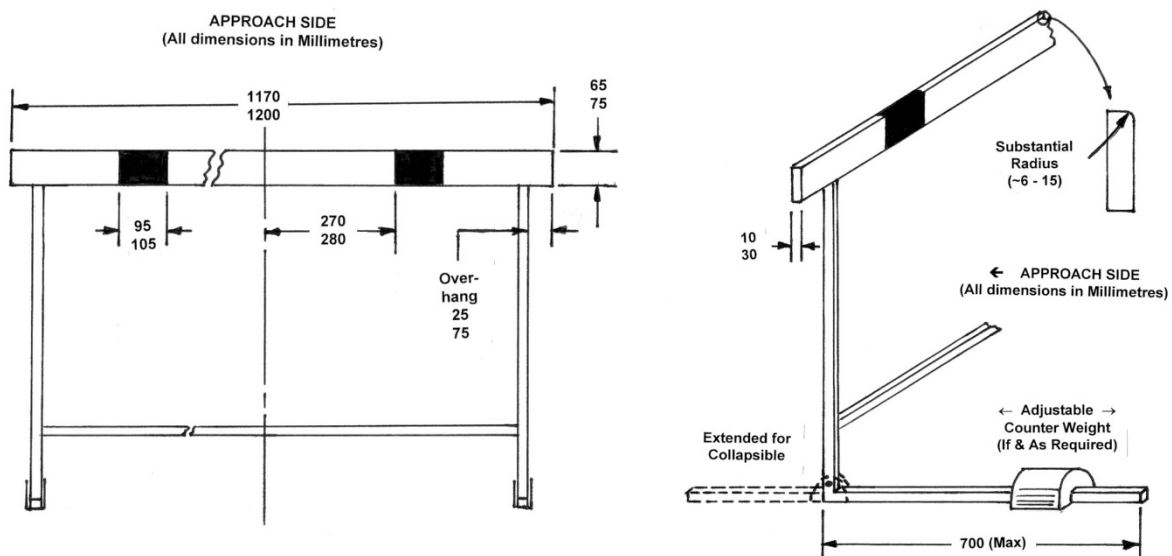

TRACK UMPIRING

(Related IAAF/LAVic Rules: Rule 127, 163)

Function

- To ensure that each athlete is given an equal opportunity to compete fairly and perform to the best of their ability.
- To act as another pair of eyes for the Referee.
- Report any infringements without fear or favour and without authority to make a final decision.

Equipment

- **White Flag or approved method:** used to signify "all clear"
- **Yellow Flag or approved method:** used to signify an "infringement"
- **Clipboard:** for holding "Infringement forms" for noting details of infringements

List of Possible Infringements

COMPETITION AREA

- Receiving assistance from inside the competition area or leaving the immediate competition area.

Note: Athletes may communicate with anyone outside the competition area, so long as it doesn't disrupt the event

- Receiving assistance through the use of any type of device that can communicate with others.
- Physical pacing by persons not currently participating in the event.

FOR LANED EVENTS

- Running out of lane.
- Off Track "excursion" (infield or outside).
- Interfering with another athlete such as, jostling, pushing, tripping, cutting off, obstructing, locking or waving arms.

FOR HURDLES

- Arms/legs into adjoining lanes.
- Legs passing outside of hurdles (lanes 1 & 8).
- Trail leg passing below the hurdle in the case of 300m hurdles where some of the hurdles are staggered.
- Falling into adjoining lane (as in laned).

FOR UNLANED EVENTS

- Interfering with another athlete such as, jostling, pushing, tripping, cutting off, obstructing, locking or waving arms.

Note: Umpires perform the same duties during a Race Walking event; however they cannot adjudicate on the rules of Race Walking.

- Off Track "excursion" (infield or outside).

FOR RELAYS

- Dropping the baton.

Note: Once dropped, the baton may only be picked up by the athlete who dropped it. Dropping the baton alone is not an infringement.

- Out of lane or off track to recover baton.

Note: Athletes can leave their lane or the course to retrieve the dropped baton, however they must exit and then re-enter at the same point, so as to not decrease the distance covered. Athletes must not interfere with any other athlete whilst retrieving their dropped baton.

- Out of lanes prior to breakline.
- Interference during Takeover or after baton change.

- Receiving the baton before or after the Takeover zone.
- Interfering with another athlete such as, jostling, pushing, tripping, cutting off, obstructing, locking or waving arms.

Note: Some of the Relay infringements may fall into the Takeover zone Officials area of responsibility, but if noted they should be reported irrespective.

Indicating "Infringements"/"All Clear"

- When all athletes have passed your location and:
No infringements have occurred: raise the white flag or approved method, to give the "all clear" to the Chief Umpire.
Wait for acknowledgment by the Chief Umpire before lowering flag or approved method.
Infringements have occurred: raise the yellow flag or approved method, and keep it raised until the Chief Umpire acknowledges, then proceed to the location of the infringement on the track and fill in the infringement form. A Referee or an Assistant will collect the report from you.
Chief Umpire will keep yellow flag raised until report is taken and passed to the Referee.

Duties of Chief Umpire

- Instruct each Track Umpire as to the duties,
- Indicate placement of each Track Umpire
- Ensure that all Track Umpires are visible
- Act as coordinator for all infringement signalling.

COURSE MARSHALL

(Related IAAF/LAVic Rules: Rule 127, 220)

Function

- To ensure that each athlete is given an equal opportunity to compete fairly and perform to the best of their ability.
- Ensure the athletes are directed where required along the course.
- Ensure any turns or loops on the course are clearly marked to avoid confusion by the athletes.
- Act as another pair of eyes for the Referee.
- Report any infringements without fear or favour and without authority to make final decisions.

Equipment

- **Communication Device:** To contact Referee/Meet Manager.
- **Clipboard:** for holding Infringement Forms for noting details of infringements

List of Possible Infringements include:**COMPETITION AREA**

- Receiving assistance from inside the competition area or leaving the immediate competition area.

Note: Athletes may communicate with anyone outside the competition area, so long as it doesn't disrupt the event

- Receiving assistance through the use of any type of device that can communicate with others.
- Physical pacing by persons not currently participating in the event.
- Interfering with another athlete such as, jostling, pushing, tripping, cutting off, obstructing, locking or waving arms.
- Off Track "excursion" (infield or outside).
- Cutting corners.

RELAYS

(Related IAAF/LAVic Rules: Rule 170)

Preparation for Event

- Ensure that all aspects of the Track and Takeover zones are safe for athletes.
- Ensure the athletes are aware of the area in which the baton must be passed, (Takeover zone).

Definitions

- **Takeover zone:** They are 20m in length and one lane in width, in which the baton must be passed.
- **Acceleration zone (U12 and above):** A zone in each lane of 10 metres in length, prior to the beginning of the Takeover zone, where the receiving athlete may begin to accelerate prior to the passing of the baton. (The baton must not be passed within this zone).
- **Check Mark:** a marker placed within a lane to denote where the athlete's acceleration is to begin.
- **Breakline:** the point where the athletes may leave their respective lanes and cross to the inside of the track (3rd runners in the 4 x200 & Medley).

Equipment

- **Baton:** smooth hollow tube, circular in cross section, made of a rigid material.
- **White Flags or approved method:** White flag to signal 'all clear'
- **Yellow Flags or approved method:** To indicate 'infringement' has taken place.

Officials Required

- Officials at each end of the Takeover zone are referred to as Takeover zone Umpires. The more Takeover zone Umpires available, the easier it is to officiate, as athletes are spread across 8 lanes and regularly arriving/leaving the Takeover zone together.

General Rules

- The baton must be carried in the hand during the event, no gloves are allowed.
- U9 – U11 athletes commence running from inside the Takeover zone. U12 and above athletes may commence running from inside the acceleration zone. The baton passing takes place within the 20m Takeover zone. The position of the baton is decisive, not the athletes body, head, feet or legs.
- If the baton is dropped, it must be picked up by the athlete, who dropped it, not by another athlete in the same team or any other person.
- Assistance to athletes in the form of pacing, pushing off or other methods is not allowed and may lead to team disqualification.
- Athletes are not to run more than one section (leg) of a relay.
- Only in those sections (legs) run in lanes, athletes may use a check mark.

Laned & Unlaned Takeover zones

LANED (4x100, 1ST & 2ND IN 4x200 & MEDLEY)

- The passing of the baton commences when both athletes are in contact with the baton – such contact must occur inside the Takeover zone and is completed when the baton is in the sole possession of the receiving athlete. The passing of the baton must not commence in the acceleration zone.

Note: Acceleration zones only apply to the U12 and above athletes; U9 - U11 athletes do not use the acceleration zones.

- Athletes should remain in their lanes after handing over the baton until the track is clear in order to avoid obstructing other athletes.

UNLANED (MEDLEY & 4x200: 3RD CHANGES)

- Athletes are lined up in lane draw order (inside to out) on a line three metres inside the beginning of the Takeover zone. The line is indicated by the placement of cones on the inside and outside of the track.
- The awaiting athletes must maintain their order and must not exchange positions at the beginning of the takeover zone.
- On completing the change, incoming athletes must clear the track quickly, endeavouring to ensure that no interference is caused to other teams.

Note: Officials are not to physically assist athletes during unlaned changeovers; however they are there to direct the athletes.

Position of Breaklines

- The position of the breakline is different depending on the event:
 - **4x200m:** at the beginning of the back straight on the third leg of the event.
 - **Medley:** at the beginning of the front straight on the third leg of the event.

Reporting Procedures for Officials

- If an infringement is noted at a Takeover zone, the Official/Umpire will raise a yellow flag or approved method, and report it to the Referee. Any infringements observed by Officials should be noted on a pre-printed form and collected by the Referee to adjudicate on the infringement.

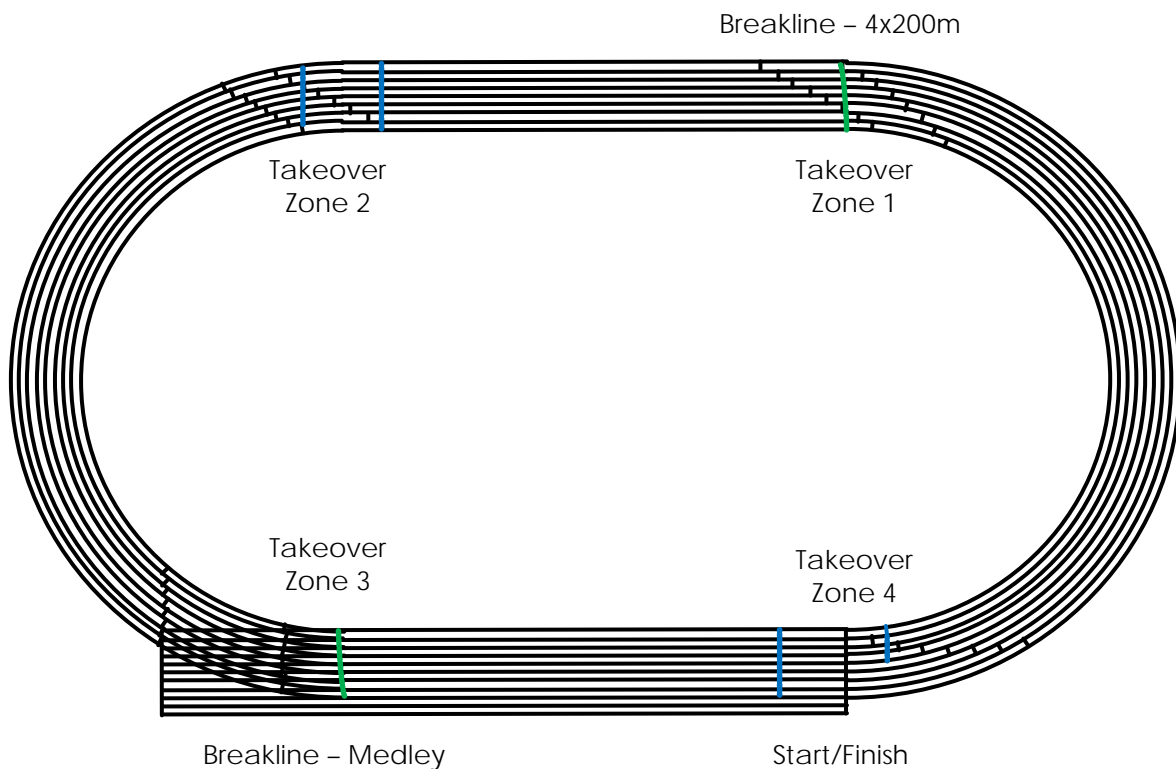

Starting Positions

- 4x100m – on 400m stagger start lines.
- 4x200m – on 4x400m stagger start lines.
- Medley – on 400m stagger start lines.

RACE WALKING

(Related IAAF/LAVic Rules: Rule 230)

Within Little Athletics Victoria there is a committee called the LAVic Race Walking Committee (RWC). This committee is responsible for further education and accreditation of Race Walking Judges. To become a Walk Judge, you must pass specific exams. Further details and contact is through the LAVic Office.

Definition

Race Walking is a progression of steps so taken that the walker makes contact with the ground, so that no visible (to the human eye) loss of contact occurs. The advancing leg must be straightened, (i.e. not bent at the knee) from the moment of first contact with the ground until the vertical upright position.

Equipment

- **Walk Jackets or Numbers:** Each venue should have enough numbered Walk Jackets or numbers to be able to conduct two consecutive events. Walk Jackets may be of one colour or of two different coloured sets with preferably sequential numbering.
- **Judging Pads:** Each Walk Judge should be issued with a walk judge's pad for recording Yellow paddles and Red cards for each event. Walk judging slips are handed to the Chief Walk Judge (or their assistant) at the conclusion of the event.
- **Chief Walk Judge's Sheet:** Each event requires a Chief Walk Judge's Master Sheet. An example may be obtained from the Office. The Chief Walk Judge is responsible for collating appropriate details based on reports received from the other walk judges. The completed Chief Walk Judge's Sheet indicates the total yellow paddles and red cards received by each athlete. The Chief Walk Judge then speaks to the athletes at the end of the race, and advises if any disqualifications have occurred. Having signed the sheet the Chief Walk Judge forwards numbers of the disqualified athletes to the recorders.

Race Walking Rules

There are two basic rules in Race Walking:

- **Contact:** The athlete must never have both feet off the ground at once.
- **Knees:** The advancing leg must be straightened (not bent at the knee) from when the foot first makes contact with the ground until the vertical upright position.

Methods of issuing a Yellow Paddle or Red Card

Walk Judges give:

- **Verbal Yellow Paddles:** for all age groups and where possible show the athlete a yellow paddle indicating the offence along with the verbal caution.
- **Verbal Red Cards:** up to and inclusive of the U10 age group.
- **Non-Verbal Red Cards:** for U11 and above age groups.

A Walk Judge may Yellow Paddle an athlete twice, once for Contact and once for Knees. However they cannot issue 2 for Knees or 2 for Contact.

EXAMPLES: U9 – U10 ATHLETES – VERBAL YELLOW PADDLES & RED CARDS

- Number 15: Caution 'Knees' - where possible show the Yellow paddle of the offence.
- Number 15: Caution 'Contact' - where possible show the Yellow paddle of the offence.
- Number 6: Red Card 'Knees'
- Athlete No 15 has received two Yellow paddles from the same Walk Judge; one for Knees and one for Contact.

Note new distances for season 2016 / 2017

U8 – up to 700 mts – Centre level only

U9 – 700 mts – all levels

U10 – U 11 – 1100 mts – all levels

U12+ - 1500 mts – all level

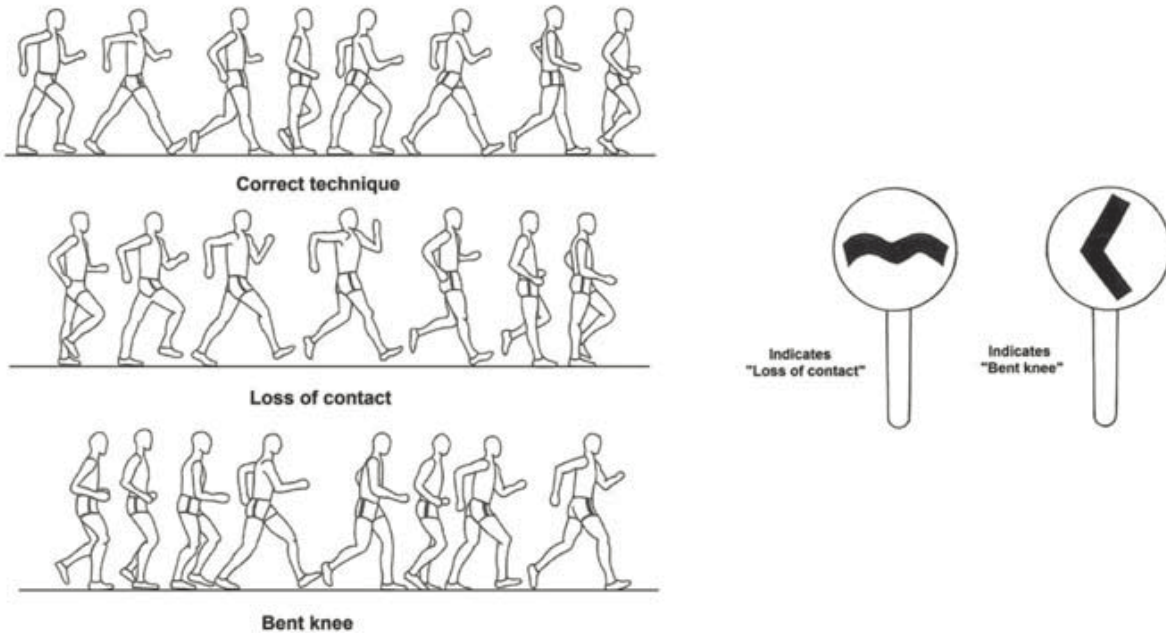

Process

1. If a Walk Judge suspects there is the possibility of an athlete infringing the rules, the Walk Judge:
 - (a) Issues a Yellow paddle informing the athlete immediately, "Number 15 Caution – Knees".
 - (b) Record this Yellow paddle on your Walk Judges slip.
 - (c) Hand the Walk Judges slip to the Chief Walk Judge as soon as the event is completed.
2. If a Walk Judge notices a definite infringement the Walk Judge should:
 - (a) Issue a Red Card (up to & including U10 age group), Verbal, "Number 10 Red Card – Contact". All other age groups, the Red Card is silent and the athletes are not informed.
 - (b) Record the Red Card listing the athlete's number and type of infringement on the judging slip.
 - (c) Hand the Walk Judges slip to the Chief Walk Judge as soon as the event is completed.

Note

1. If in doubt, give the benefit of any doubt to the athlete. If the Walk Judge can't form a definite opinion on an infringement, they should not penalise the athlete.
2. It is essential that the advancing foot be in contact with the ground before the rear foot is lifted.
3. Each Walk Judge may Yellow paddle an athlete once for loss of contact & bent knee. These Yellow paddles do not count towards disqualification.
4. Each Walk Judge may only Red Card the same athlete once.
5. The Chief Walk Judge is normally the highest graded Walk Judge officiating.
6. The Chief Walk Judge is the ONLY Judge who informs the athlete of their disqualification.
7. Each Walk Judge must hand in their Judge's slip to the Chief Walk Judge as soon as the event has finished.
8. Decisions of the Judging Panel are final.
9. When there are less than 4 Walk Judges the number of Red Cards for disqualification of an athlete is in the table below, otherwise three Red cards are required for disqualification.
10. It is best to view an athlete from side on, not from behind

11. In certain circumstances Walk Judges may not be able to stand on the outer edge of the track, e.g., when hurdles are in progress. However it is ideal to stand in lanes 5-8 to gain the best view.
12. Do not pre-Judge any athlete & do not be biased.
13. Walk Judges must not confer with each other regarding their opinions (Yellow Paddles/Red cards) of athletes.
14. The Chief Walk Judge (or their Assistant) must instruct athletes on the rules of Race Walking and conduct of the event, prior to the start.
15. Walk Judges should be placed for maximum coverage of the track. Suggested positions are as diagram below:

Judging Sectors on Track

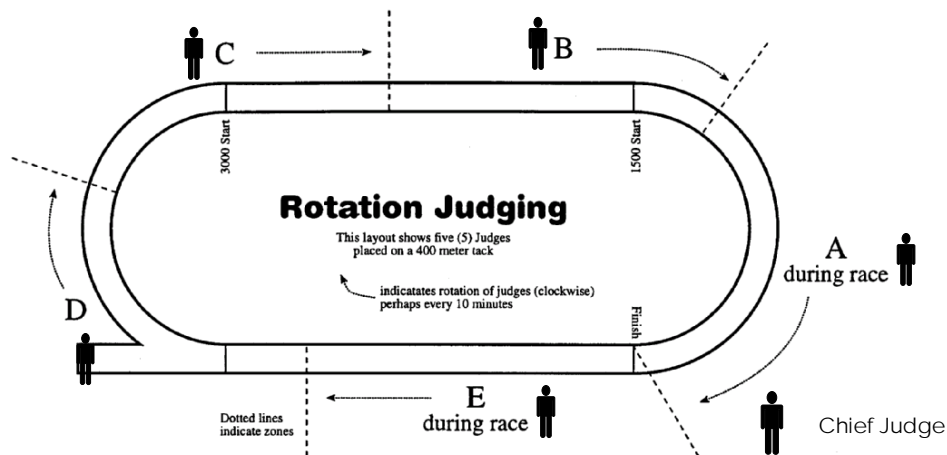

Proper Area of Observation

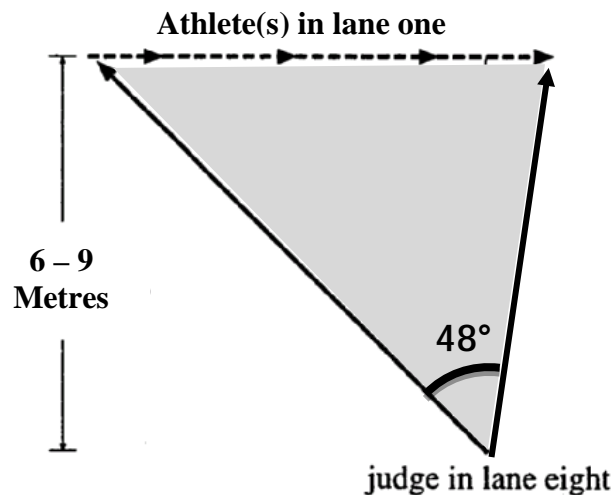

Disqualifications

The maximum number of Walk Judges for a track event is six. The following should apply:

No. of Walk Judges	No. of Red Cards for Disqualification
2 or 3	2
4 - 6	3

HIGH JUMP

(Related IAAF/LAVic Rules: Rule 180, 181, 182)

Preparation for Event

- Ensure that all aspects of landing area and run up are safe for the athletes.
- Ensure that the brackets that support the crossbars are facing the opposite upright.
- Allow athletes a practice jump(s) to check their run up if possible.
- Set bar at correct starting height (see measuring bar height below).
- The uprights and landing area should be designed so that there is a clearance of at least 100mm between them to avoid displacement of the crossbar through movement of the landing bag coming into contact with the uprights.

Event Safety

- The uprights may be moved during a competition only if the Judge in consultation with the Referee considers the take-off or landing area has become dangerous.
- The landing area should be maintained in a safe condition. If a number of small bags are used then it should be regularly checked to ensure that there are no gaps.
- It is also good practice to place smaller mats at the back and ends of landing area.

Equipment

- **Uprights:** x 2 fitted with a suitable adjustable bracket for holding crossbar
- **Crossbar:** (circular in cross section) with square mounting blocks at each for resting bar on brackets
- **Measuring Stick:** or tape
- **Landing Bag:** (minimum of 600mm thick)
- **Broom:** For keeping Run-up area clean
- **Marker/s:** For athletes to mark their run-up (tape) - allowed 2 markers.

Officials Required

- **Two officials at the uprights:** to return the crossbar to the supports.
- **One official to judge the jump:** this official is the Chief Official for this event
- **One official to record**

Measuring the Crossbar Height

- The height is checked with the measuring stick perpendicular to the ground to the top of the lowest point of the crossbar, i.e., the middle. The height of the crossbar at the uprights is also taken to ensure that the bar is level. Knowing the difference, i.e., "sag" of the bar is useful when raising the bar as the height at the uprights will be higher than in the middle.

General Rules

U 8 Scissors

- The Scissor technique will be the only allowable technique performed in High Jump for the Under 8 age groups. In season 2017-2018 this will include the U9's and in season 2018-2019 also include both the U9 & U10's.
- The U8 athletes must take off from one foot, clear the bar in a predominately vertical position and the first contact made on the landing area must be made by one or both feet.
- It shall be a valid scissor jump if all other relevant high jump rules are adhered to, and:
 - a) The head of the competitor does not go over the bar before the leading foot (the foot of the leg closest to the bar at take-off);
 - b) The head of the competitor is not below the buttocks when the buttocks clear the bar, and
 - c) The competitor's lead foot touches the mat before any other part of the body.

U9 – U16

- Prior to the competition the judges will announce to the athletes the starting height.
- An athlete may commence jumping at any height above the starting height.
- Three consecutive failures regardless of the height will eliminate the athlete.
- At the end of the round the bar should be raised in 5cm increments. When there are 4 or less athletes remaining the increments will be 2cms.
- The final athlete may continue to jump, at height rises agreed with the Chief Judge or Referee, until the athlete has three consecutive failures.
- An athlete may pass on the second or third trial at a particular height (after failing the first or second time) and still jump at a subsequent height.
- An athlete may approach the bar from any angle. An athlete must take-off from one foot only. Diving over the bar is not recommended.
- If the bar falls after an athlete has landed and left the Mat, it MAY still be considered a failure. It is the decision of the judge as to whether contact by the athlete or some other factor caused the bar to fall, i.e. Wind gusts.
- If an athlete fails to commence an attempt within 60 seconds of their name being called by the Official in charge, a failure will be recorded. An athlete may abort an attempt (balk) as many times as they like provided that the final attempt is commenced in 60 seconds.
- If the athlete touches the ground including the landing area beyond the vertical plane through the nearer edge of the crossbar, either between or outside the uprights with any part of his body, without first clearing the bar it is considered a failure. However, if when the athlete jumps, they touch the landing area with their foot and in the opinion of the Judge, no advantage is gained, the jump for that reason should not be considered a failure
- If the athlete touches the crossbar or the vertical section of the uprights when running up without jumping, it is considered a failure. The rule does not apply to touching a base plate (unless it is beyond the zero line)

Starting Heights for State Championships

AGE	U9	U10	U11	U12	U13	U14	U15
GIRLS	0.90	1.00	1.10	1.15	1.25	1.30	1.35
BOYS	0.95	1.10	1.15	1.25	1.30	1.40	1.45

- Regions starting heights will be 10cm below State.
- Centres use age and skill appropriate starting heights.

Recording:

- **O** indicates a Clearance or valid jump.
- **X** indicates a Failure
- **-** indicates a "Pass" or "Did not attempt at that height "

Athlete	1.05	1.10	1.15	1.20	1.25	1.30	1.33
A	-	XO	O	XO	O	XXO	XXX
B	O	O	O	X-	XO	XXO	XXX
C	O	O	X-	O	XXO	XXO	XXX
D	O	X-	O	XXO	XXO	XO	XXX
E	X-	X-	X				

Determining the Results

- The athlete who clears the greatest height is the winner.
- If there is a tie:
 - (a) The athlete with the lowest number of jumps at the height at which the tie occurs will be awarded the higher place. If the tie remains, the athlete with the lowest total of failures throughout the competition up to and including the height last cleared will be awarded the higher place.
 - (b) If the tie still remains and the Organising Committee has advised a jump off will occur then:
 - (i) If it concerns first place, the athletes tying will have one more jump at that height at which they failed, and if no decision is reached the bar will then be lowered or raised to the heights which will be announced by the Chief Judge of the event, they will then attempt one jump at each height until the tie is broken. Athletes will be awarded the best of all their jumps, including those in a jump off.
 - (ii) If it concerns any other place the athletes will be awarded equal place in the competition.
 - (iii) If the Organising Committee has advised No jump off will occur then all tied places will be equal.

Athlete	Best	Failures	Place
A	1.30	4	E2
B	1.30	4	E2
C	1.30	5	4
D	1.30		1
E	NH		NH

- All cleared 1.30m and all failed at 1.33m.
- D wins with the lowest number of attempts at 1.30, only 2
- A & B is equal 2nd with 4 failures. C is 4th with 5 failures.
- State Results will always show "NH" when an athlete fails to record a measurable height.

LONG JUMP

(Related IAAF/LAVic Rules: Rule 180, 184, 185)

Preparation for Event

- Ensure sand in the pit is level with run-up.
- Sand may need to be watered if it is dry.
- Allow athletes a practice jump(s) to check their run up if possible.
- Markers are to be available/distributed to all athletes to mark their run-up.
- The distance from the edge of the pit to the front edge of the take-off area for:
 - U6-U8: should not be less than 500mm or more than 2 metres.
 - U9 and above: should not be less than 500mm and not more than 3 metres.

Event Safety

- Before first event of the day, the pit needs to be carefully dug over to loosen sand and whilst turning and levelling sand an inspection and removal of objects such as sticks, stones, etc. to avoid injury to the athletes.

Equipment

- **Take-off area:** (mat, sand, tape or board):

U6-U8	1.22m x 1.0m	mat with thin layer of sand
U9-U10	1.22m x 0.5m	mat with thin layer of sand
U11 and above	1.22m x 0.2m	tape/board

Note: If the runway is less than 1.22m wide the width of the mat should be reduced to the width of the runway

- **Tape Measures:** 1 for measuring (20 metres), 1 for Run ups (50metres)
- **Rake:** To level the landing area sand after each trial
- **Broom:** For keeping Runway clear of sand
- **Shovel:** For digging over landing area and moving sand
- **Bucket/Hose/Watering Can:** For keeping sand damp
- **Hand Brush:** To sweep take-off area after each jump
- **Spike:** To hold zero end of tape at the nearest edge of the mark made by the athlete on landing.
- **Place Tickets:** To record performance for each athlete
- **Recording Sheet:** For recording all performances
- **Marker:** For athletes to mark the start point of their run-up, an additional (longer) tape may be made available for use by the athletes to measure their run-up

Officials Required

- **One official at take-off area.** Tasks include watching for foul jumps, measuring. (see measuring the jump)
- **Two officials at side of pit.** Tasks include finding break (imprint) made in sand (see measuring the jump) and raking & levelling the sand in the pit.
- **One official for recording.**

Number of Trials

- Each athlete is entitled to 3 trials, differences may apply at Centres and State Championships and some athletes may have 4 trials.

General Rules

- The athletes fail if they employ any form of somersaulting.
- Once competition has begun, athletes are not permitted to use the competition runway for practice purposes.

Trials

- The athlete must place take-off foot on or before the take-off area nearer to the landing area. If any part of foot is beyond the front edge or if the entire foot is outside either end of the take-off area then it is a foul / invalid trial and recorded as a "No Jump".
- Markers may not be placed on runway but may be placed alongside the runway.
- Markers are not permitted in the landing area/pit.
- If during the run-up, an athlete touches the ground beyond the take-off line with any part of the body, whether running up with or without jumping; it will be deemed a trial even if it is not completed. This will be recorded as a "No Jump".
- If after completing the jump an athlete walks back through the landing area towards the take-off area it is a 'No Jump'.
- In the course of landing an athlete must not touch the ground outside the landing area nearer to the take-off point than the nearest break (imprint) in the landing area.

Measuring the Jump

- All jumps must be measured from the nearest break in the landing area made by any part of the body to the front edge of the imprint made by the take-off foot (U6-U10) or to the take-off line or its extension (U11 and above). The selected point is marked by the spike and the zero end of the tape is held at the spike.
- In the case of an (U6-U10) athlete taking off before reaching the take-off area, the jump is measured from the nearest break in the landing area made by any part of the body to the back edge of the take-off area. The measurement must be taken perpendicular to the back of the take-off area or its extension.
- The tape is drawn tight and the distance is measured to the nearest centimetre below the distance jumped unless the reading is a whole centimetre.

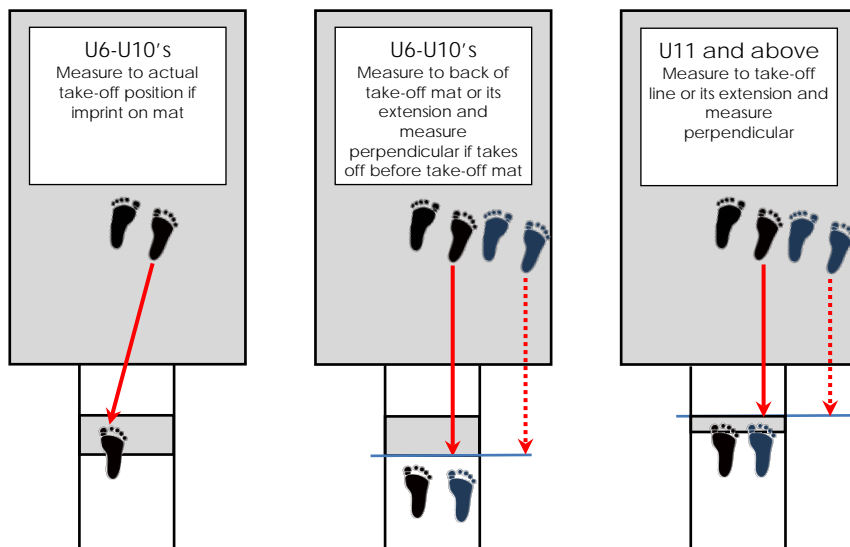

Recording

Best performances should be circled or highlighted

The athlete who has the longest measured distance from all jumps recorded is the winner

Ties are broken by referring to the next best jump

Athlete	1st Trial	2nd Trial	3rd Trial	Best	Place
A	4.75	X	4.62	4.75	4
B	5.35	4.92	5.87	5.87	2
C	4.65	4.35	4.75	4.75	3
D	5.87	5.35	5.03	5.87	1
E	X	X	X	ND	ND

- D beats B on count back to 3rd Best Trial
- C beats A on count back to 2nd Best Trial
- X should be used to indicate an Invalid Trial
- State Results will always show "ND" when an athlete fails to record a measurable trial.

TRIPLE JUMP*(Related IAAF/LAVic Rules: Rule 180, 184, 186)***Definition**

- The Triple Jump consists of three distinct skills performed at speed in a continuous action as follows:
 - **Hop:** During the hop the athlete uses the same foot for take-off and landing.
 - **Step:** Athlete lands on the opposite foot (to that used for the hop).
 - **Jump:** Athlete performs a jump from the "step" foot and lands in the pit.

Event Safety

- Before first event of the day, the pit needs to be carefully dug over to loosen sand and whilst turning and levelling sand an inspection and removal of objects such as sticks, stones, etc. to avoid injury to the athletes.
- Officials may need to direct athletes to use a shorter mat placement if they fail to make the pit.

Preparation for Event

- Ensure sand in the pit is level with the run-up.
- Sand may need to be watered if it is dry.
- Allow jumpers a practice jump(s) to check their run up if possible.
- Markers are to be made available to all athletes to mark their run-up.
- The take-off area minimum distance varies for each athlete as safety is paramount and is the overriding factor.

Equipment

- **Take-off area:** (mat, sand, tape or board):

U6 - U8	Not an approved Event	
U9 - U10	1.22m x 0.05m	Mat with sand
U11 and above	1.22m x 0.2m	tape/board

NOTE : U9-U10 Triple Jump is not offered at Region or State, can be offered at Centre level for season 2016/2017 only.

- **Tape Measures:** 1 for measuring (20 metres), 1 for Run ups (50metres)
- **Rake:** To level the landing area sand after each trial
- **Broom:** For keeping Runway clear of sand
- **Shovel:** For digging over Landing Area and moving sand
- **Bucket/Hose/Watering Can:** For keeping sand damp
- **Hand Brush:** To sweep take-off area after each jump.
- **Spike:** To hold zero end of tape at the nearest edge of the mark made by the jumper on landing
- **Place Tickets:** To record performance for each athlete
- **Recording Sheet:** For recording all performances at the venue
- **Marker:** For athletes to mark the start point of their run-up, an additional (longer) tape may be made available for use by the athletes to measure their run-up.

Officials Required

- **One official at take-off area.** Tasks include watching for foul jumps, measuring (see below for measuring the jump).
- **Two officials at side of pit.** Tasks include finding break (imprint) made in sand (see below for measuring the jump) and raking & levelling the sand in the pit.
- **One official for recording.**

Number of Trials

- Each athlete is entitled to 3 trials, differences may apply at Centres and State Championships and some athletes may have 4 trials.
- Once competition has begun, athletes are not permitted to use the competition runway for practice purposes.

Trials

- The athlete must take-off from one foot;
- The athlete must place take-off foot on or before the take-off area nearer to the landing area. If any part of foot is beyond the front edge or if the entire foot is outside either end of the take-off area then it is a foul / invalid trial and recorded as a "No Jump".
- Markers may not be placed on runway but may be placed alongside runway.
- Markers are not permitted in the landing area/pit, or beyond the take-off area.
- If during the run-up, an athlete touches the ground beyond the take-off line with any part of the body, whether running up with or without jumping; it will be deemed a trial even if it is not completed. This will be recorded as a "No Jump".
- If after completing the jump an athlete walks back through the landing area towards the take-off area it is a 'No Jump'.
- In the course of landing a jumper must not touch the ground outside the landing area nearer to the take-off point than the nearest break (imprint) in the landing area.

Note

1. The trailing leg is allowed to make contact with the ground during the trial without penalty.
2. It is recommended that athletes should be grouped to trial on take-off area position while maintaining the order within each group.
3. An athlete may change the position of their take off; they must however inform the recorder first.

Measuring the Jump

- All jumps must be measured from the nearest break in the landing area made by any part of the body to the take-off line or its extension (U11 and above). The selected point is marked by the spike and the zero end of the tape is held at the spike.
- The tape is drawn tight and the distance is measured to the nearest centimetre below the distance jumped unless the reading is a whole centimetre.

Recording

- Best performances should be circled or highlighted
- The jumper who has the longest measured distance from all jumps recorded is the winner.
- Ties are broken by referring to the next best jump

Athlete	1st Trial	2nd Trial	3rd Trial	Best	Place
A	10.76	X	9.62	10.76	4
B	11.35	10.92	11.88	11.88	2
C	10.65	10.35	10.76	10.76	3
D	11.88	11.35	11.03	11.88	1
E	X	X	X	ND	ND

- D beats B on count back to 3rd Best Trial
- C beats A on count back to 2nd Best Trial
- X should be used to indicate an Invalid Trial
- State Results will always show "ND" when a jumper fails to record a measurable trial.

DISCUS

(Related IAAF/LAVic Rules: Rule 180, 187, 189)

Event Safety

- Discus circles should be enclosed with a cage, and an extending fence to protect other areas on which events may be conducted should also be considered.
- The Chief Official should stand outside the cage alongside the ring in a safe position on the right hand side of a right handed thrower and vice-versa.
- Apart from the Chief Official and the Official on the sector line and/or spiking, everyone should stand behind the athlete, and at least 1m away from the safety cage and the landing sector should be clear. Where there isn't a cage, officials and athletes must stand at least 2m behind the thrower except the Chief Official and the Official on the sector line and/or spiking and the landing sector should be clear.
- The discus should be CARRIED back to the circle - never thrown.

Officials Required

- **Two officials at throwing circle.** Tasks include watching for foul throws, measuring and pulling the end of the tape back through the centre of the circle.
- **One official at side of Sector.** Tasks include locating and marking the point of impact of the discus and returning the discus to the circle.
- **One official for recording.**

Equipment

- **Sector and Circle:** Clearly marked (as below)
- **Tape Measure:** (50-100 metres)
- **Discus:** (as specified below, provided by the Organising Committee)
- **Spike:** To hold zero end of tape at the nearest edge of the mark made by the discus on landing
- **Place Tickets:** To record performance for each athlete
- **Recording Sheet:** For recording all performances at the venue
- **Cloth:** To wipe and clean the discus
- **Broom:** To sweep the surface of the discus circle.

Venue Dimensions

- The discus is thrown from a circle into a sector of 34.92°. The inside diameter of the circle is 2.50mts. All lines used to mark the circle and sector, are 50mm wide.

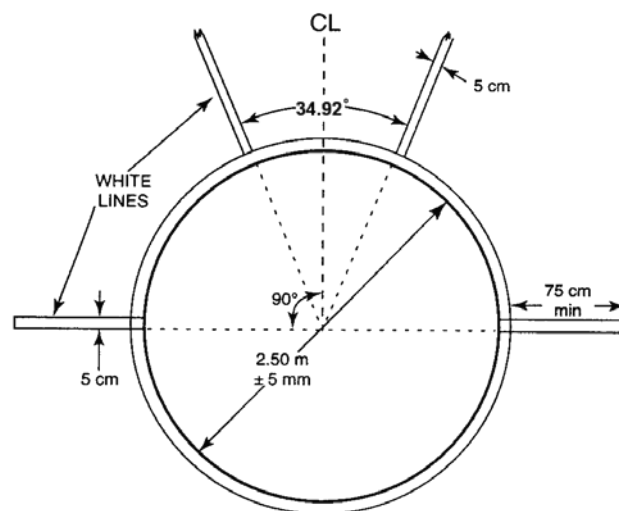

LAYOUT OF DISCUS CIRCLE

Implement Weights

U6 - U8	350g (recommended)
U9 - U10	500g
U11G - U13G & U11B - U12B	750g
U14G - U16G & U13B - U16B	1kg

Number of Trials

- Each athlete is entitled to 3 trials, differences may apply at Centres and State Championships and some athletes may have 4 trials.

Valid Trial

- The trial must be commenced from a stationary position inside the circle.
- The athlete must not leave the circle until the discus has landed.
- The athlete must not touch the top of the circle or the ground outside the circle during the trial with any part of their body. They are allowed to touch the inside of the circle.
- For a valid trial the discus must fall so that the point of impact is within the inner edge of the lines marking the sectors.
- The athlete may enter the circle from any direction (preferably from the rear half of the circle) but must exit from the rear half of the circle.
- The athlete may during the course of each trial, stop and place the discus down in the circle and then recommence the trial again, providing that no other infringement has occurred.
- Once competition has begun, athletes will not be permitted to use the circle or ground within the sector for practice trials with or without implements.

Method of Measurement

- Officials select the imprint mark made by the discus on landing closest to the circle. The selected point is marked by the spike and the zero end of the tape is held at the spike.
- The tape is drawn tight through the centre of the circle.
- The distance is measured at the point where the tape crosses the inner edge of the circle.
- Each measurement is to the nearest cm below the distance thrown unless the reading is a whole centimetre.
- If the discus hits the cage and deflects back into the sector it will be a valid trial and measured providing no other infringement occurs.

Recording

- Best performances should be circled or highlighted.
- Ties are broken by referring to the next best throw.

Athlete	1st Trial	2nd Trial	3rd Trial	Best	Place
A	14.75	X	14.62	14.75	4
B	15.35	14.92	15.88	15.88	2
C	14.65	14.35	14.75	14.75	3
D	15.88	15.35	15.03	15.88	1
E	X	X	X	ND	ND

- D beats B on count back to 3rd best throw
- C beats A on count back to 2nd best throw
- X should be used to indicate an invalid trial
- State Results will always show "ND" when an athlete fails to record a measurable trial.

SHOT PUT

(Related IAAF/LAVic Rules: Rule 180, 187, 188)

Event Safety

- The Chief Official should stand alongside the ring in a safe position on the right hand side of a right handed thrower and vice versa.
- Apart from the Chief Official and the official on the sector line and/or spiking, everyone should stand 2m behind the athlete and the landing sector should be clear.
- The shot should be CARRIED back to the circle - never thrown.

Equipment

- **Sector and Circle:** Clearly marked (as below)
- **Tape Measure:** (20 metres)
- **Shot:** (as specified below, provided by the Organising Committee)
- **Spike:** To hold zero end of tape at the nearest edge of the mark made by the shot on landing
- **Place Tickets:** Record performance for each athlete.
- **Recording Sheet:** For recording all performances at the venue
- **Cloth:** To wipe and clean the shots.
- **Broom:** To sweep the surface of shot put circle

Officials Required

- **Two officials at putting circle:** Tasks include watching for foul throws, measuring and pulling the end of the tape back through the centre of the circle.
- **One official at side of Sector:** Tasks include locating and marking the point of impact of the shot and returning the shot to the circle.
- **One official for recording.**

Venue Dimensions

- The shot is 'put' from a circle into a Sector of 34.92° . The inside diameter of the circle is 2.135m. All lines used to mark the circle and sectors are 50mm wide.
- A stop/kick board measuring 1.22m Long, 100mm high and 114mm wide will be used.

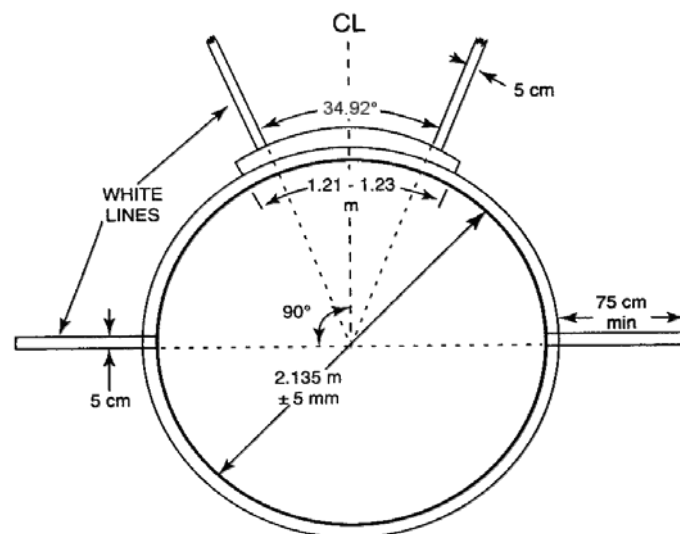

LAYOUT OF SHOT CIRCLE

Implement Weights

U6 - U7	1kg (recommended)
U8	1.5kg (recommended)
U9G - U12G & U9B - U11B	2kg
U13G - U16G & U12B - U14B	3kg
U15B - U16B	4kg

Number of Trials

- Each athlete is entitled to 3 trials, differences may apply at Centres and State Championships and some athletes may have 4 trials.

Valid Trial

- The trial must be commenced from a stationary position inside the circle.
- The athlete must not leave the circle until the shot has landed.
- The athlete must not touch the top of the circle or stop/kick board, or the ground outside the circle during the trial with any part of their body. They are allowed to touch the inside of the stop/kick board.
- The shot must land in a manner whereby the 'impact mark' is within the inner edges of the lines marking the sector.
- The athlete may enter the circle from any direction (preferably from the rear half of the circle) but must exit from the rear half of the circle.
- The shot must be put from the shoulder with one hand only. At the start of the trial the shot should touch or be in close proximity to the neck or chin and should not be dropped below this position during the action of putting.
- The shot must not be brought from behind the line of the shoulders.
- The athlete may during the course of each trial, stop and place the shot down in the circle and then recommence the trial again, providing that no other infringement has occurred.
- Once competition has begun, athletes will not be permitted to use the circle or ground within the sector for practice trials with or without implements.

Method of Measurement

- Officials select the 'imprint mark' made by the shot on landing closest to the circle. The selected point is marked by the spike and the zero end of the tape is held at the spike.
- The tape is drawn tight through the centre of the circle.
- The distance is measured at the point where the tape crosses the inner edge of the circle.
- Each measurement is to the nearest cm below the distance put unless the reading is a whole centimetre.

Recording

Best performances should be circled or highlighted.

Ties are broken by referring to the next best throw.

Athlete	1st Trial	2nd Trial	3rd Trial	Best	Place
A	4.76	X	4.62	4.76	4
B	5.35	4.92	5.88	5.88	2
C	4.65	4.35	4.76	4.76	3
D	5.88	5.35	5.03	5.88	1
E	X	X	X	ND	ND

- D beats B on count back to 3rd best put
- C beats A on count back to 2nd best put
- X should be used to indicate an invalid trial
- State Results will always show "ND" when an athlete fails to record a measurable trial.

JAVELIN

(Related IAAF/LAVic Rules: Rule 180, 187, 193)

Warning: Javelins are dangerous Implements

The javelin is a form of spear and as such is a lethal weapon; it can be deflected by gusts of wind.

Event Safety

- The Chief Official should stand alongside the runway in a safe position on the right hand side of a right handed thrower and vice-versa.
- Apart from the Official on the Sector Line, everyone should stand behind the athlete and the landing Sector should be clear.
- The javelin should be CARRIED back to the runway in a vertical position, tip down- never thrown.

Equipment

- **Runway:** Clearly marked (as below)
- **Tape Measure:** (50-100 metres)
- **Javelin:** (As specified below and provided by Organising Committee)
- **Spike:** To hold zero end of tape where the tip of the metal head first struck the ground.
- **Place Tickets:** Record performance for each athlete.
- **Recording Sheet:** For recording all performances at venue.
- **Cloth:** To wipe and clean the javelins.
- **Broom:** To sweep the javelin runway.
- **Marker:** For athletes to mark the start point of their run-up.

Officials Required

- **Two officials at throwing arc.** Tasks include watching for foul throws, measuring and pulling the end of the tape back through the centre of the circle of which the arc is a part (8mts from the arc).
- **One official at side of the Sector.** Tasks include finding and marking the point of impact of the javelin tip and returning the javelin.
- **One official for recording.**

Venue Dimensions

- The length of the runway should be 30-36.5m and the width is 4mts with the lines 50mm wide. The "arc" line should be 70mm in width. Markers can only be used at the side of runway.
- The Landing Sector lines are 50mm wide, such that the inner edge of the lines, if extended, would pass roughly through the two Intersections of the inner edges of the arc, and the parallel lines marking the runway and intersect at the centre of the circle of which the arc is a part, 8mts from the arc line. The Sector is thus 28.95 °.

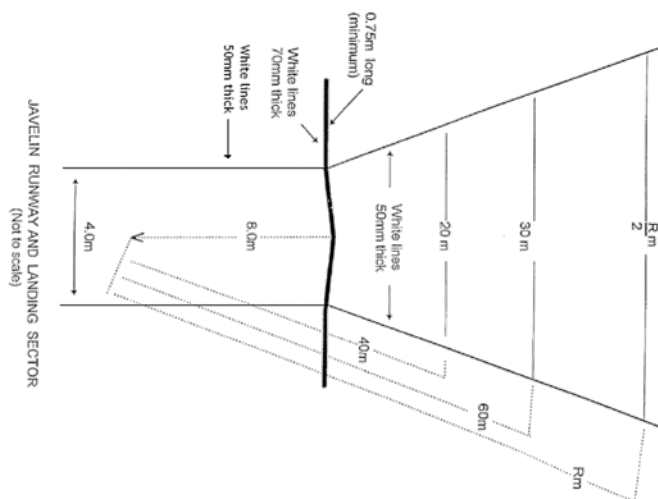

Implement Weights

U11B - U12B & U11G - U14G	400g
U15G - U16G	500g
U13B - U14B	600g
U15B- U16B	700g

Number of Trials

- Each athlete is entitled to 3 trials, differences may apply at Centres and State Championships and some athletes may have 4 trials
- Allow athletes a practice throw(s) to check their run-up if possible

Valid Trial

- The javelin must be held at the grip. It should be thrown over the shoulder or upper part of the throwing arm, and must never be slung or hurled. Non-orthodox styles are not permitted.
- At no time during the throw, until the javelin has been launched into the air, may the athlete turn completely around, so that their back is toward the throwing arc.
- A trial will be valid only if the tip of the metal head strikes the ground before any other part of the javelin. The javelin does not have to stick in, but marking is easier if it does. When a javelin descends at a low angle to the ground it may bounce shortly before producing what looks like a fair landing. This must be carefully watched to see that the tip impacts first.
- The athlete must not leave the runway until the javelin has impacted the ground.
- When leaving the runway the athlete must not leave forward of the throwing arc.
- The athlete may during the course of each trial, stop and place the javelin down inside or outside the runway, leave the runway, then return to begin a fresh trial, providing that no other infringement has occurred.

Method of Measurement

- The measurement of each throw will be made from where the tip of the metal head first strikes the ground to the inside edge of the arc along a line from the point of landing to the centre of the circle of which the arc is part.
- The selected point is marked by the spike and the zero end of the tape is held at the spike.
- The tape is drawn tight through the centre of the circle of which the arc is a part (8mts from the arc).
- The distance is measured at the point where the tape crosses the inner edge of the runway arc.
- Each measurement is to the nearest cm below the distance thrown unless the reading is a whole centimetre.

Recording

- Best performances should be circled or highlighted
- Ties are broken by referring to the next best throw

Athlete	1st Trial	2nd Trial	3rd Trial	Best	Place
A	24.75	X	24.62	24.75	4
B	25.35	24.92	25.87	25.87	2
C	24.65	24.35	24.75	24.75	3
D	25.87	25.35	25.03	25.87	1
E	X	X	X	ND	ND

- D beats B on count back to 3rd Best Throw
- C beats A on count back to 2nd Best Throw
- X should be used to indicate an Invalid Trial
- State Results will always show "ND" when an athlete fails to record a measurable trial.

EQUIPMENT SPECIFICATIONS

Hurdles

Distance	Age Group	Flights	Height of Hurdles	Distance To 1st Hurdle	Distance Between Hurdles	Distance to Finish
60m (Orange)	U9	6	45cm	12m	7m	13m
	U10, U11	6	60cm	12m	7m	13m
	U12	6	68cm	12m	7m	13m
80m (Black)	U13, U14	9	76cm	12m	7m	12m
90m (White)	U14B, U15G, U16G	9	76cm	13m	8m	13m
100m (Yellow)	U15B, U16B	10	76cm	13m	8.5m	10.5m
200m (Green)	U13	5	68cm	20m	35m	40m
	U14	5	76cm	20m	35m	40m
300m (Green)	U15, U16	7	76cm	50m	35m	40m

Field Implements

Boys				Girls			
Age Group	Event			Age Group	Event		
	Shot Put	Discus Throw	Javelin Throw		Shot Put	Discus Throw	Javelin Throw
U6	1kg	350g	-	U6	1kg	350g	-
U7	1kg	350g	-	U7	1kg	350g	-
U8	1.5kg	350g	-	U8	1.5kg	350g	-
U9	2kg	500g	-	U9	2kg	500g	-
U10	2kg	500g	-	U10	2kg	500g	-
U11	2kg	750g	400g	U11	2kg	750g	400g
U12	3kg	750g	400g	U12	2kg	750g	400g
U13	3kg	1kg	600g	U13	3kg	750g	400g
U14	3kg	1kg	600g	U14	3kg	1kg	400g
U15	4kg	1kg	700g	U15	3kg	1kg	500g
U16	4kg	1kg	700g	U16	3kg	1kg	500g

Triple Jump		Long Jump		
Age Group	Front Edge Of Mat Or Board From Edge Of Pit (Suggested Only)	Age Group	Take Off Area	Front Edge Of Mat Or Board From Edge Of Pit
		U6 – U8	1.0m Mat	Min 0.5m – Max 2m
U11, U12G	5/6/7/8m	U9 – U10	0.5m Mat	Min 0.5m – Max 3m
U12B	6/7/8/9m	U11 –U16	0.2m Board	Min 0.5m – Max 3m
U13	7/8/9m			
U14 - U16	8/9/11/13m			

OTHER RESOURCES

There are a number of online resources available to you to help build knowledge and to give assistance when embarking on your journey.

We have listed three sites which we believe will be beneficial to you when starting out to officiate.

LAVic Regulation 8 – Competition Rules and IAAF Rule Book

LAVic Region & State Competitions are conducted in accordance with the Competition Rules of the IAAF currently in force with modifications provided for in Regulation 8 – Competition Rules – Version 2.0 (Released August 2016)

Where it has been decided the IAAF Rules are not indicative or correct for athletes in the age groups covered by LAVic, the IAAF Rule or part thereof has been rewritten to reflect the nature and abilities of athletes in the various age groups.

Centres are encouraged to use these rules as guideline for their weekly Centre Competitions

Online copies of the current LAVic Regulation 8 & the IAAF Rule Book can be found online on the LAVic website.

WEBSITE

<http://www.lavic.com.au/Competition/Rules-Regulations>



Australian Sports Commission - Introductory Level Officiating General Principles online course

The Introductory Level Officiating General Principles online course has been developed to assist officials in learning the basic skills they will need to officiate effectively.

ABOUT THE COURSE

The course contains three modules, which cover a range of general officiating topics, including ethical responsibilities of officials, preparation for officiating, safety, communication, dealing with conflict and people management. The course takes approximately four hours to complete, and there is assessment included within the course. Officials have six months to complete the course after they register.

ENROLLING

To enrol in the course, go to the Australian Sports Commission's Online learning portal.

WEBSITE:

<http://www.ausport.gov.au/participating/resources/officials/onlineofficial>



Play by the Rules

The website is a comprehensive portal which provides the latest news, articles, events, tools and resources around safe, fair and inclusive sport. The site provides information on commonly occurring issues in sport, including what the law says about the matter, and provides practical ideas by your role (e.g., coach, official, player) about 'what to do now' and 'what to do next'. There's stuff on managing risks, dealing with complaints and template codes and policies for clubs to download and adapt for their own use. There are also fact sheets, guides and links on where to get additional help.

WEBSITE

<http://www.playbytherules.net.au/>

